

MAX70
70 lbs Thrust
24 Volt 42 Amps

for use with "J" serial numbers
3-year warranty from the date of sale

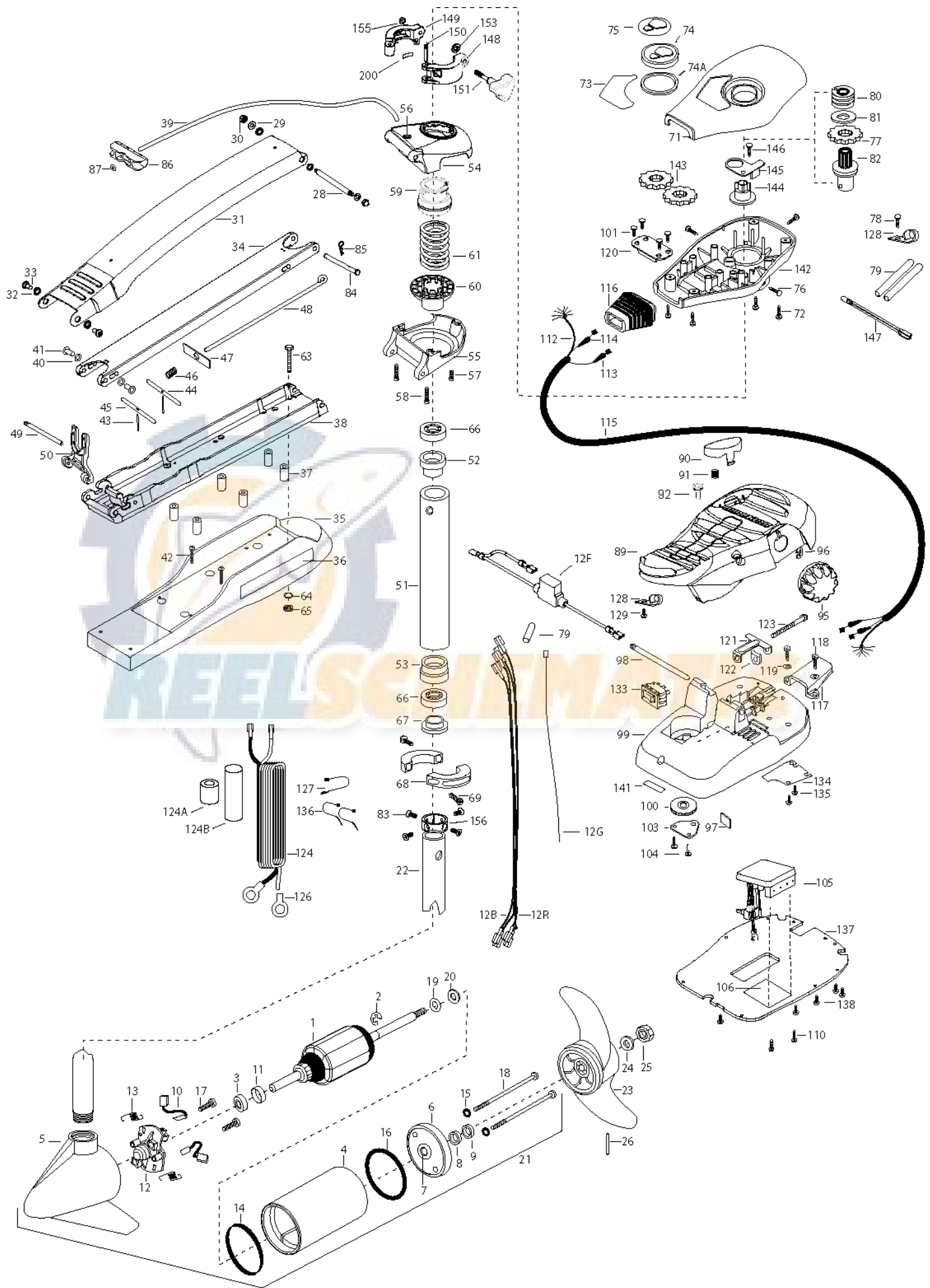

1	2-100-119	ARMATURE ASSEMBLY	48	2153604	EYE SHAFT- 2LOCKBAR LG PLTD	101	2223430	SCREW- #8X3/4 PPH TYPE 25 SS [4.EA]
2	788-015	RETAINING RING	49	2260506	HINGE-PIN HEADLESS ZINC	103	2266400	COVER- PULLEY
3	140-010	BALL BEARING	50	2293811	YOKE- MAXXUM MOUNT,POLYPROPYLENE	104	2301310	SCREW- 8-18 X 1/2 [4.EA]
4	431-005	CENTER HOUSING ASSEMBLY	■	2772016	TUBE W/BEARING RACE ASSEMBLY 52"	105	2264054	CNTROL BOARD ASSEMBLY 24-36V MAX
5	421-065	HOUSING BRUSH END 3.62 62"		2772014	TUBE W/BEARING RACE ASSEMBLY 62"	106	2365107	INSULATING PAD (2.3X3.2)
	421-068	BRUSH HOUSING ASSY 3.62 US1 62"		2272067	TUBE OUTER-24" 4 HOLES 48"-52"	110	2223455	SCREW- 10-32 X 1/2" [2.EA]
	421-069	BRUSH HOUSING ASSY 3.62 US1 62"	51	2272068	TUBE OUTER-34" 4 HOLES 62"	111	2211410	EXTENSION CABLE- SONAR ONLY
6	2-400-101	PLAIN END HOUSING ASSEMBLY	52	2266260	BEARING RACE	112	2261220	WIRE HARNESS AT & MAX
7	144-049	BEARING - FLANGE (SERVICE CENTER ONLY)	53	2266220	BEARING RACE- STEEL	113	2267505	CABLE ASSEMBLY- RIGHT (5')
8	880-003	SEAL	■	2991762	BOWGUARD ASSEMBLY- FT CTRL,FW 52"	114	2267515	CABLE ASSEMBLY- LEFT (5')
9	880-006	SEAL WITH SHIELD		2991763	BOWGUARD ASSEMBLY- FT CTRL,FW 62"	115	2265430	CABLE JACKET (5')
10	188-037	BRUSH ASSEMBLY [2.EA]	54	2772319	BRACKET BASE TOP/INSERT ASSEMBLY	116	2265110	BOOT- CONTROL BOX
11	725-050	BRUSH RETENTION- PAPER TUBE	55	2991771	BRKT BOTTOM/BEARING FW ASSEMBLY 52"	117	2265115	BOOT- FOOT PEDAL BASE
12	738-036	BRUSH PLATE W/HOLDER		2991770	BRKT BOTTOM/BEARING FW ASSEMBLY 62"	118	2372100	SCREW- 8-18X5/8 THD [2.EA]
12B	640-008	LEADWIRE 10 GA	56	2772352	EYELET- ROPE KIT	119	2261714	WASHER- MAXXUM FT PDL [2.EA]
12R	640-107	LEADWIRE RED 10 GA	57	2263423	SCREW 5/16-18 X 1" SHCS ZINC	120	2261901	BRACKET- CONDUIT
	649-316	GROUND WIRE 62"	58	2263425	SCREW 5/16-18 X 2 1/2" SHCS [2.EA]	121	2263210	BRACKET- CONDUIT ADJUST
	2218200	FUSE HOLDER (US MOTORS ONLY)	59	2071541	SPRING SLEEVE- UPPER	122	2263104	NYLOCK KEEPER
13	975-040	SPRING - TORSION [2.EA]	60	2071535	SPRING SLEEVE- LOWER	123	2266366	SCREW- 1/4-20X2" STL PPH
14	337-036	GASKET	61	2262712	SPRING- BOWGUARD, FC PAINTED	124	2261233	LEADWIRE- VARIABLE
15	701-008	O-RING, THRU-BOLT [2.EA]	■	2994830	BAG ASSEMBLY- MAXXUM	126	2020700	TERMINAL RING- 3/8" [2.EA]
16	701-081	O-RING	*63	2263431	SCREW- 1/4-20 X 3.5 PPH [6.EA]	127	2256300	TIE WRAP- 5.5' BLACK
17	830-007	SCREW-8-32 [2.EA]	*64	2261713	WASHER- 1/4 FLAT S/S [6.EA]	128	2263201	CLAMP WIRE HARNESS MICRO [2.EA]
18	830-008	THRU-BOLT 10-32X9.2 [2.EA]	*65	2263103	NUT- 1/4-20 NYLOCK-JAM SS [6.EA]	129	2332103	SCREW- 6-20X3/8 THD (SS)
19	990-067	WASHER- STEEL THRUST	■	2994832	BAG ASSEMBLY- MAX101 62"	133	2254031	SWITCH- MOM/OFF/CON
20	990-070	WASHER- NYLATRON [2.EA]	66	2266000	BEARING BALL- STEEL [2.EA]	134	2266412	SWITCH PLATE- FT PEDAL
21	2106031	MOTOR ASSEMBLY 24V F/W 52" SONAR	*67	2266115	BEARING CONE	135	2332103	SCREW- 6-20X3/8 THD SS [2.EA]
	2096031	MOTOR ASSEMBLY 24V F/W 52"	*68	2261622	COLLAR HALF- ALUM. [2.EA]	136	2256301	TIE WRAP- 5.5' WHITE [2.EA]
22	2032006	TUBE- COMPOSITE 52" W/4 HOLE	*69	2263453	SCREW- 1/4-20X3/4 [2.EA]	137	2774511	BOTTOM PLATE- MAXXUM FT
	2032005	TUBE- COMPOSITE 48" W/4 HOLE	71	2260283	CONTROL BOX COVER- MAXXUM	138	2372100	SCREW-8 X 1/2" (SS) [5.EA]
■	1378131	PROPELLER KIT	72	2372100	SCREW- 8-18 X 5/8 THD [4.EA]	139	2263455	SCREW- #12-14X1/2 THR FRM [4.EA]
23	2091160	PROPELLER W.WEDGE 2	73	2265643	DECAL- COVER MAX70/FC	140	2265126	BUMPER PAD- FOOT PEDAL [4.EA]
24	2151726	WASHER-5/16 SS		2265646	DECAL - COVER MAX70 /FC US	141	2266610	DECAL- ON/OFF SWITCH
25	2053101	NUT-PROP NYLOC	74	2260150	POINTER DISC TRNSLCNT RED	142	2262535	CONTROL BOX- PLASTIC
26	2092600	PIN-DRIVE	74A	2261733	WASHER-FOAM, INDICATOR	143	2267800	GEAR- INDICATOR [2.EA]
28	2262605	PIN- BWGRD UPPER THREADED ZP	75	2265800	DECAL- INDICATOR	144	2262220	INDICATOR- DRIVE
29	2261722	WASHER- FLAT[2.EA]	76	2053414	SCREW- 8-32 X 1/2 TRI-LOBE [3. EA]	145	2261905	BRACKET/INDICATOR
30	2223100	NUT- TENSION 5/16-18 SS [2.EA]	77	2267800	GEAR- INDICATOR	146	2301310	SCREW- 8-18X1/2"
■	2991841	MOUNT- BOW ASSY, LNG FW 52" W/O BGRD	78	2372100	SCREW- 8-18 X 5/8	147	2264015	LIGHT/INDICATOR
	2991842	MOUNT- BOW ASSY, LNG FW 62" W/O BGRD	79	2355410	SHRINK TUBE- 3/8 OD X 2" [3.EA]	■	2991556	CLAMP COLLAR ASSEMBLY
31	2264246	ARM-UPPER LONG FW	80	2232360	PULLEY- CABLE DRUM	148	2071550	CLAMP COLLAR "A"
32	2293501	BUSHING- STAINLESS STEEL [4.EA]	81	2261730	WASHER- NYLON A/T CON	149	2071555	CLAMP COLLAR "B"
33	2263500	BOLT- SHOULDER MAXXUM [2.EA]	82	2996247	TOP BEARING RACE /PINION DRIVE	150	2072621	PIN-KNURLED
34	2774317	ARM-LOWER ASSEMBLY, LONG,FW,EXTRA [INCLUDES 39, 43-47, 86,87]	83	2223468	SCREW- 8-32 X 7/16 [4.EA]	151	2281505	KNOB-CLAMP COLLAR
			84	2262607	PIN- CLEVIS ZP MAXXUM BWGRD	153	2071718	WASHER #10 NYLON RETAINING
35	2263913	MOTOR REST LONG FW	85	2260805	CLIP- SPRING ZP MAX BG	155	2073102	NUT - HEX 1/4 - 28 SS
36	2265514	DECAL- MAXXUM MOTOR REST [2.EA]	86	2150400	PULL- GRIP	156	2071560	SPLIT COLLAR
37	2261505	SPACER- MOTOR REST [6.EA]	87	2151700	WASHER- EYE SHAFT(.562 OD)	157	2263804	STRAP - VELCRO 30.5"
38	2773986	BOWPLATE- W/INSERT	89	2994496	FOOT PEDAL/PLUG ASSEMBLY	200	2075120	URETHANE PAD
39	2251601	ROPE (40"), MAXXUM MOUNT	90	2993705	PUSH- BUTTON MAGNET ASSY			
40	2261708	WASHER- 3/8X1/2X.010 SS [2.EA]	91	2302732	SPRING- LOWER PEDAL		62" ONLY	
41	2267318	BEARING NYLINER [2.EA]	92	2260810	CLIP, REED SWITCH	158	2030710	CONNECTOR BUTT [2.EA]
42	2263434	SCREW, 8-18X1" PPH [2.EA]	95	2280115	KNOB- SPEED CONTROL (VAR)	159	2030317	WIRE EXTENSION 18" RED
43	2152610	SPRING- PIN LOCKBAR [2.EA]	96	2263000	E-RING THU-ARC	160	2030316	WIRE EXTENSION 18" BLACK
44	2233600	LOCK BAR- BOW MOUNT	97	2266413	TENSION SCREW PLATE FTPEDAL	161	2375400	SHRINK TUBE 1/4ODX1-3/4 [2.EA]
45	2233602	LOCK BAR REAR - ZINC	*98	2260511	PIN- PIVOT A/T FT PDL			
46	2152700	SPRING- LOCKBAR CAD.PLTD	99	2774550	FT PEDAL BASE/PIN ASSEMBLY			
47	2262703	SPRING STOP- MAXXUM	100	2262301	PULLEY- FOOT PEDAL			

2888460 Seal & Oring Kit

Max 70 is 24-volt only!

OPTIONAL BROWN WIRE *
SEE BOAT WIRING DIAGRAM
FIL MARRON OPTIONNEL *
ÉQUIPÉS DE SONAR. VOYEZ LE SCHÉMA DE CÂBLAGE DU BATEAU.

